



INDEPENDENT
PIPE
PRODUCTS, INC.

Factory Mutual Approved Class 150 & Class 200 HDPE Pipe & Pipe Fittings

DESIGN-FLOW®



“Better by Design”®

FM Approved HDPE
Pipe & Fittings
Submittal Catalog

June 1, 2010
Version 1.4.2

TOC	Table Of Contents	18-1
1. Design-Flow® HDPE	IPS HDPE Pipe (Iron Pipe Size 2"-24")	18-2
FM APPROVED	DIPS HDPE Pipe (Ductile Iron Pipe Size 4"-24")	18-3
	PE 4710 HDPE Physical Properties - FM	18-4
2. Flange Adapters	IPS Flange Adapter (2" to 36")	18-5
FM APPROVED	DIPS Flange Adapter (4" to 30")	18-6
3. Convuluted Bolt Rings	IPS Ductile Iron-Stainless Steel Bolt Ring (2"-36")	18-7
FM APPROVED	DIPS Ductile Iron-Stainless Steel Bolt Ring (4"- 24")	18-8
	Bolt Ring Materials Physical Properties	18-9
4. Reducer Components	IPS Concentric Reducer (2" x to x 24")	18-10
FM APPROVED	DIPS Concentric Reducer (4" x to x 24")	18-11
5. Branch Saddles	IPS Branch Saddle (main x 2" - 12" outlet)	18-12
FM APPROVED	DIPS Branch Saddle (main x 2" - 12" outlet)	18-13
6. Water-Stops	IPS & DIPS (2" to 24")	18-14
FM APPROVED		
7. MJ Adapters & Kits	IPS & DIPS MJAdapter Kit (2" - 24")	18-15
FM APPROVED	MJ Adapter Gland & Accessory Pack (2" - 24")	18-16
8. Elbows	90° & 45° IPS Molded Elbow (2" to 6")	18-17
FM APPROVED	90° IPS 3 Segment Fabricated (4" to 24")	18-18
	90° IPS 5 Segment Fabricated (4" - 24")	18-19
	45° IPS 2 Segment Fabricated (4" to 24")	18-20
	45° IPS 3 Segment Fabricated (4" to 24")	18-21
	22.5° IPS 2 Segment Fabricated (4" to 24")	18-22
	90° DIPS 3 Segment Fabricated (4" to 24")	18-23
	90° DIPS 5 Segment Fabricated (4" to 24")	18-24
	45° DIPS 2 Segment Fabricated (4" to 24")	18-25
	45° DIPS 3 Segment Fabricated (4" to 24")	18-26
	22.5° DIPS 2 Segment Fabricated (4" to 24")	18-27
9. Tees	IPS Molded Line Tee (2" - 6")	18-28
FM APPROVED	IPS Fabricated Line Tee (4" - 24")	18-29
	DIPS Fabricated Line Tee (4" - 24")	18-30
	IPS Br. Saddle Reducing Tee (2" x to x 24")	18-31
	DIPS Br. Saddle Reducing Tee (4" x to x 24")	18-32



IPS HDPE PIPE PE4710



Factory Mutual Approved High Density Polyethylene Pipe

FM 1613 . ASTM F 714 . ASTM D 3035 . AWWA C901/C906 . NSF - 61

IPS Size		DR 11 CLASS 150 WPR @ 150 psi			DR 9 CLASS 200 WPR @ 200 psi		
IPS Pipe Size	Pipe OD (in)	Avg ID (in)	Min Wall (in)	Weight (lbs/ft)	Avg ID (in)	Min Wall (in)	Weight (lbs/ft)
2"	2.375	1.917	0.216	0.64	1.815	0.264	0.77
3"	3.500	2.826	0.318	1.39	2.675	0.389	1.66
4"	4.500	3.633	0.409	2.31	3.440	0.500	2.75
5"	5.563	4.490	0.506	3.52	4.253	0.618	4.20
6"	6.625	5.349	0.602	5.00	5.065	0.736	5.96
8"	8.625	6.963	0.784	8.47	6.594	0.958	10.11
10"	10.750	8.679	0.977	13.16	8.219	1.194	15.70
12"	12.750	10.293	1.159	18.51	9.746	1.417	22.08
14"	14.000	11.301	1.273	22.32	10.701	1.556	26.63
16"	16.000	12.915	1.455	29.15	12.231	1.778	34.78
18"	18.000	14.532	1.636	36.89	13.760	2.000	44.02
20"	20.000	16.146	1.818	45.54	15.289	2.222	54.34
22"	22.000	17.760	2.000	55.10	16.819	2.444	65.75
24"	24.000	19.374	2.182	65.58	18.346	2.667	78.25

Pressure Ratings are calculated using 0.50 design factor for HDS at 73°F as listed in FM 1613. Temperature considerations may require use of additional design factors. Pipe weights are calculated in accordance with PPI TR-7. Average inside diameter is calculated with nominal OD and minimum wall thickness plus 6%. Actual ID's will vary and are controlled by the dimensions and tolerances listed in the applicable pipe specifications.

$$DR = \frac{\text{Pipe OD (inches)}}{\text{Minimum Wall Thickness (inches)}}$$

Per FM 1613 & AWWA C906, the working pressure rating equals the pressure class, with an allowance included in the WPR for pressure surge. The pressure and surge design basis for polyethylene pipe is different from the PVC and DI pipe design basis.

The Long-Term Hydrostatic Strength of PE3608/PE4710 Polyethylene Pipe is 1600 psi at 73.4 F. The performance & physical properties of PE4710 meet and exceed the requirements of PE3608.



DIPS HDPE PIPE

PE4710



Factory Mutual Approved High Density Polyethylene Pipe

FM 1613 . ASTM F 714 . ASTM D 3035 . AWWA C901/C906 . NSF - 61

DIPS Size		DR 11 CLASS 150 WPR @ 150 psi			DR 9 CLASS 200 WPR @ 200 psi		
DIPS Pipe Size	Pipe OD (in)	Avg ID (in)	Min Wall (in)	Weight (lbs/ft)	Avg ID (in)	Min Wall (in)	Weight (lbs/ft)
4"	4.800	3.876	0.436	2.62	3.670	0.533	3.13
6"	6.900	5.571	0.627	5.42	5.274	0.767	6.47
8"	9.050	7.305	0.823	9.32	6.917	1.006	11.13
10"	11.100	8.961	1.009	14.03	8.486	1.233	16.74
12"	13.200	10.656	1.200	19.84	10.090	1.467	23.67
14"	15.300	12.351	1.391	26.65	11.696	1.700	31.80
16"	17.400	14.046	1.582	34.47	13.302	1.933	41.13
18"	19.500	15.741	1.773	43.29	14.906	2.167	51.66
20"	21.600	17.436	1.964	53.12	16.512	2.400	63.38
24"	25.800	20.829	2.345	75.78	19.722	2.867	90.43

Pressure Ratings are calculated using 0.50 design factor for HDS at 73°F as listed in FM 1613. Temperature considerations may require use of additional design factors. Pipe weights are calculated in accordance with PPI TR-7. Average inside diameter is calculated with nominal OD and minimum wall thickness plus 6%. Actual ID's will vary and are controlled by the dimensions and tolerances listed in the applicable pipe specifications.

$$DR = \frac{\text{Pipe OD (inches)}}{\text{Minimum Wall Thickness (inches)}}$$

Per FM 1613 & AWWA C906, the working pressure rating equals the pressure class, with an allowance included in the WPR for pressure surge. The pressure and surge design basis for polyethylene pipe is different from the PVC and DI pipe design basis.

The Long-Term Hydrostatic Strength of PE3608/PE4710 Polyethylene Pipe is 1600 psi at 73.4 F. The performance & physical properties of PE4710 meet and exceed the requirements of PE3608.

INDEPENDENT PIPE PRODUCTS, INC.



“BETTER BY DESIGN”®

Specification Sheet #P10

DESIGN-FLOW® High Density Polyethylene Pipe PE3408 / PE3608 Nominal Physical Properties*



Typical Specification	ASTM Test Method	Nominal Values
Density	ASTM D 1505	.955 gm / cm ³
Melt Index ¹	ASTM D 1238	6.5 gm / 10 min.
Tensile Strength		
@ Yield (2 in/min)	ASTM D 638	3300 psi
@ Break (2 in/min)	ASTM D 638	4500 psi
Hydrostatic Design Basis (HDB)		
@ 23° C (73.4° F)	ASTM D 2837	1600 psi
@ 60° C (140° F)	ASTM D 2837	1000 psi
HDB Design Factor (DF)	PPI TR-4	0.50
Elongation @ Break (2 in/min)	ASTM D 638	>750%
Flexural Modulus ²	ASTM D 790	125,000 psi
Notched Izod Impact Strength	ASTM D 256	6.0 ft-lbf / in
Hardness (Shore D)	ASTM D 2240	66
Brittleness Temperature	ASTM D 746	< -103 ° F
Environmental Stress Crack Resistance ³	ASTM D 1693	>5000 hrs
NSF	STANDARD 61	APPROVED
Cell Classification	ASTM D 3350	345464C (min)
Vicat Softening Point	ASTM D 1525	257 ° F

FM APPROVED DESIGN-FLOW® High Density Polyethylene Pipe is manufactured to FM 1613, ASTM F 714, ASTM D 3035, AWWA C901/C906 and NSF 61 standards as applicable. Standard color of pipe is black with white print line.

Notes: ¹ 190° C / 21,600 g; ² 2% Secant - Method 1

*This list of typical physical properties is intended for basic characterization of the material and does not represent specific determinations of specifications. The physical properties values reported herein were determined on compression molded specimens prepared in accordance with procedure C of ASTM D 4703 and may differ from specimens taken from pipe.

1-800-499-6927

Page 18 - 4

www.indpipe.net

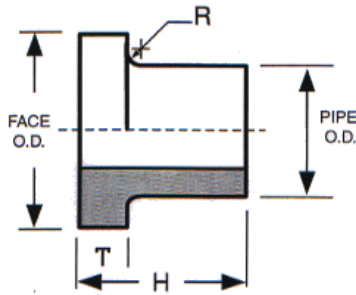

FM IPS Flange Adapters

Pressure Rated for DR Ordered

(Dimensions in Inches)

Nominal Size	H (OAL)	T	Face Diameter	R (Radius)	Class	DR	Weight (lbs)
2"	6.0	0.39	3.94	1/4	200 150	9 11	1 1
3"	6.0	0.63	5.00	1/4	200 150	9 11	2 2
4"	6.0	0.54	6.00	3/8	200 150	9 11	3 3
6"	8.0	0.78 0.78	8.50	3/8	200 150	9 11	8 7
8"	11.0	1.00	10.63	3/8	200 150	9 11	11 10
10"	11.0	1.49 1.22	12.75	3/8	200 150	9 11	19 18
12"	11.0	1.77 1.45	15.00	3/8	200 150	9 11	25 24
14"	11.0	1.94 1.60	17.50	1/2	200 150	9 11	49 40
16"	12.0	2.22 1.82	20.00	1/2	200 150	9 11	74 60
18"	12.0	2.50 2.05	21.12	1/2	200 150	9 11	79 64
20"	12.0	2.78 2.27	23.50	1/2	200 150	9 11	81 66
22"	12.0	3.06 2.50	25.60	1/2	200 150	9 11	83 68
24"	14.0	3.33 2.73	28.00	1/2	200 150	9 11	97 79
26"	15.0	3.61 2.96	30.00	1/2	200 150	9 11	143 117
28"	15.7 15.0	3.89 3.18	32.30	1/2	200 150	9 11	158 129
30"	15.8 15.0	4.17 3.41	34.30	1/2	200 150	9 11	164 134
32"	15.0	3.64	36.50	1/2	150	11	163
34"	15.0	3.86	38.50	1/2	150	11	208
36"	16.5	4.09	40.80	1/2	150	11	218

FM APPROVED DESIGN-FLOW® High Density Polyethylene Pipe Fittings meet dimensions and requirements of FM 1613. ASTM D 3261, ASTM F 2206, ASTM F 714, ASTM D 3035, AWWA C901/C906 and NSF 61 standards as applicable.

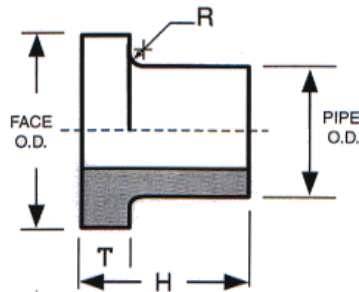

FM DIPS Flange Adapters Ductile Iron Pipe Sizes

Pressure Rated for DR Ordered
(Dimensions in Inches)

DIPS Nominal Size	H (OAL)	T	Face Diameter	R (Radius)	Class	DR	Weight (lbs)
4"	6.0	0.67	6.625	7/16	200	9	4
		0.55			150	11	3
6"	8.0	0.96	8.625	7/16	200	9	6
		0.78			150	11	4
8"	9.0	1.26	10.750	7/16	200	9	8
		1.03			150	11	6
10"	9.0	1.54	12.750	7/16	200	9	13
		1.26			150	11	10
12"	11.0	1.83	15.000	7/16	200	9	21
		1.50			150	11	17
14"	11.0	2.13	17.500	7/16	200	9	35
		1.74			150	11	28
16"	12.0	2.42	20.000	7/16	200	9	43
		1.98			150	11	35
18"	12.0	2.71	21.500	7/16	200	9	56
		2.22			150	11	46
20"	12.0	3.00	23.600	7/16	200	9	68
		2.46			150	11	55
24"	14.8	3.58	27.800	7/16	200	9	99
	14.0	2.93			150	11	81

FM APPROVED DESIGN-FLOW® High Density Polyethylene Pipe Fittings meet dimensions and requirements of FM 1613, ASTM D 3261, ASTM F 2206, ASTM F 714, ASTM D 3035, AWWA C901/C906 and NSF 61 standards as applicable.

INDEPENDENT PIPE PRODUCTS, INC.



“BETTER BY DESIGN”®



DESIGN-FLOW®

Convolute - Ductile Iron & Stainless

FM IPS Bolt Rings

Designed Specifically for use with HDPE Flange Adapters*

ASME / ANSI B16.5, B16.47^{ser.A} CL150

B16.1 CL125 AWWA C207 B,D & E

(Dimensions in Inches)

U.S. Patent # 7,401,821

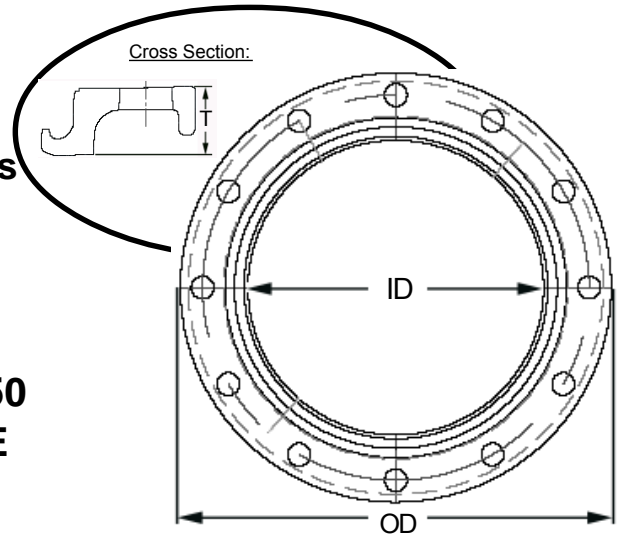

IPS Nominal Size	T (Thickness)	OD	ID	Bolt Hole Circle	Number Of Bolt Holes	Diameter Of Bolt Holes	Class	Actual WPR Rating	Weight (lbs)
2"	.75	6.00	2.50	4.69	4	3/4"	200 150	275	2.7
3"	.94	7.50	3.63	6.00	4	3/4"	200 150	275	4.5
4"	.94	9.00	4.63	7.50	8	3/4"	200 150	275	5.5
6"	1.00	11.00	6.75	9.50	8	7/8"	200 150	275	7.5
8"	1.13	13.50	8.75	11.75	8	7/8"	200 150	275	12
10"	1.19	16.00	10.94	14.25	12	1"	200 150	275	15
12"	1.50 1.25	19.00	13.00	17.00	12	1"	200 150	275 160	25 24
14"	1.63 1.38	21.00	14.38	18.75	12	1-1/8"	200 150	275 160	35 29
16"	1.84 1.63	23.50	16.38	21.25	16	1-1/8"	200 150	275 160	48 39
18"	2.00 1.70	25.00	18.38	22.75	16	1-1/4"	200 150	275 160	53 42
20"	2.23 1.84	27.50	20.38	25.00	20	1-1/4"	200 150	275 160	70 57
22"	2.41	29.50	22.38	27.25	20	1-3/8"	200 150	275	80
24"	2.56 2.16	32.00	24.38	29.50	20	1-3/8"	200 150	275 160	103 80
26"	2.50	34.25	26.38	31.75	24	1-3/8"	200 150	200	109
28"	2.59	36.50	28.38	34.00	28	1-3/8"	200 150	200	130
30"	3.00* 2.47	39.00* 38.75	30.25* 30.38	36.00	28	1-3/8"	200* 150	200* 160	368* 139
32"	2.56	41.75	32.38	38.50	28	1-3/8"	150	160	165
34"	2.88	43.75	34.38	40.50	32	1-5/8"	150	160	191
36"	3.00	46.00	36.38	42.75	32	1-5/8"	150	160	214

* Indicates flat plate / lap joint design, material is A36 carbon steel.

WPR (working pressure rating) is for free-floating rings on HDPE flange adapters and includes a 2:1 safety factor. 150# bolt-hole pattern. Convolute bolt rings are available in stainless steel 316 or ductile iron ASTM A536 GR 65/45/12. Ductile iron bolt rings are available with bright red oil based enamel paint, epoxy coating or galvanized finish.

1-800-499-6927

Page 18 - 7

www.indpipe.net



DESIGN-FLOW®

Convuluted - Ductile Iron & Stainless

FM DIPS Bolt Rings

Designed Specifically for use with HDPE Flange Adapters*

ASME / ANSI B16.5, B16.47^{Ser.A} CL150

B16.1 CL125 AWWA C207 B,D & E

(Dimensions in Inches)

U.S. Patent # 7,401,821

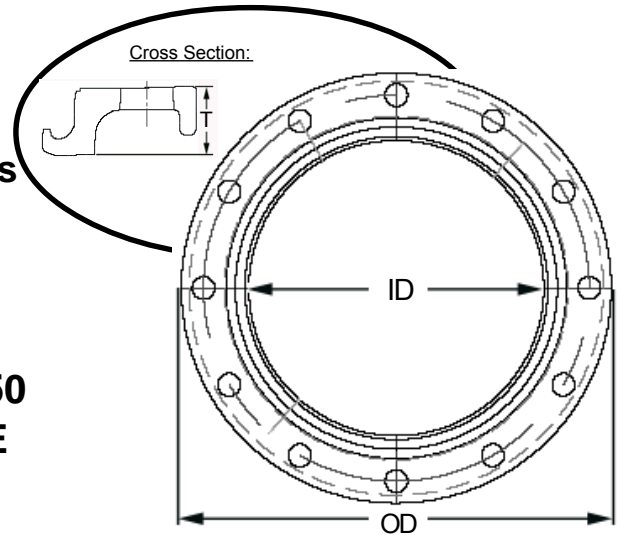

DIPS Nominal Size	T (Thickness)	OD	ID	Bolt Hole Circle	Number Of Bolt Holes	Diameter Of Bolt Holes	Class	Actual WPR Rating	Weight (lbs)
4"	.94	9.00	4.90	7.50	8	3/4"	200 150	275	5
6"	1.00	11.00	7.00	9.50	8	7/8"	200 150	275	8
8"	1.13	13.50	9.19	11.75	8	7/8"	200 150	275	11
10"	1.19	16.00	11.25	14.25	12	1"	200 150	275	16
12"	1.50	19.00	13.38	17.00	12	1"	200 150	275	26
14"	1.63	21.00	15.49	18.75	12	1-1/8"	200 150	275	31
16"	1.84	23.50	17.59	21.25	16	1-1/8"	200 150	275	42
18"	2.00	25.00	19.70	22.75	16	1-1/4"	200 150	275	51
20"	2.23	27.50	21.85	25.00	20	1-1/4"	200 150	275	61
24"	2.56	32.00	26.05	29.50	20	1-3/8"	200 150	275	94

* Indicates flat plate / lap joint design, material is A36 carbon steel.

WPR (working pressure rating) is for free-floating rings on HDPE flange adapters and includes a 2:1 safety factor. 150# bolt-hole pattern. Convuluted bolt rings are available in stainless steel 316 or ductile iron ASTM A536 GR 65/45/12. Ductile iron bolt rings are available with blue oil based enamel paint, epoxy coating or galvanized finish.

INDEPENDENT PIPE PRODUCTS, INC.



“BETTER BY DESIGN”®

Specification Sheet #B1-FM



DESIGN-FLOW®
U.S. Patent # 7,401,821

FM APPROVED

**Design-Flow® Convoluted
FM Ductile Iron & Stainless
Steel Bolt Rings**

**Metals & Coatings
Physical Properties**

METALS & ALLOYS		
Type of Material	ASTM Standard	Comments
Ductile Iron	ASTM A536	Grade 65-45-12
Stainless Steel 316	ASTM A531	Grade CF8M
PAINTS & SURFACE TREATMENTS		
Type of Material	ASTM Standard	Comments
Oil Based Enamel Paint	ASTM B117 Salt Spray	100+ Hours
Epxoy Based Paint	ASTM B117 Salt Spray	500+ Hours
E-Coat	ASTM B117 Salt Spray	1000+ Hours
Hot Dip Galvanizing	ASTM A153	5 mils
	ASTM G-85 Salt Fog	2000 Hours
Aqua-Armor Metal Jacket®	ASTM B117 Salt Spray	2500+ Hours
Fusion Bonded Epoxy Coating	ASTM A775 FBE	10 MILS to 26 MILS
	ASTM A972 FBE	10 MILS to 26 MILS
	ASTM B117 Salt Spray	3000+ Hours



FM IPS Reducers (Dimensions in Inches)

STYLE A
“compact”

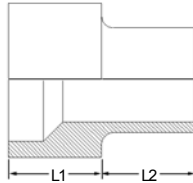

STYLE B
“fabricated”

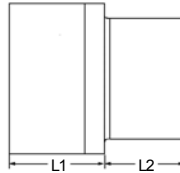

STYLE C
“traditional”

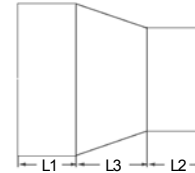

IPS Nominal Size	Style	L1	L2	L3	Class	DR	Weight (lbs)
3" x 2"	C	3.22	2.50	.93	200	9	1
					150	11	1
4" x 2"	C	2.75	2.75	1.66	200	9	2
					150	11	1
4" x 3"	C	3.00	2.50	0.88	200	9	2
					150	11	1
6" x 4"	A	4.00	4.00	-	200	9	4
					150	11	3
8" x 6"	A	4.00	4.00	-	200	9	7
					150	11	6
10" x 8"	A	6.00	6.00	-	200	9	16
					150	11	13
12" x 10"	A	6.00	6.00	-	200	9	24
					150	11	20
14" x 12"	A	7.00	7.00	-	200	9	34
					150	11	28
16" x 14"	A	7.00	7.00	-	200	9	43
					150	11	36
18" x 16"	A	7.00	7.00	-	200	9	57
					150	11	47
20" x 18"	A	7.00	7.00	-	200	9	69
					150	11	56
22" x 20"	A	7.00	7.00	-	200	9	84
					150	11	69
24" x 22"	A	9.00	9.00	-	200	9	103
					150	11	84

FM APPROVED DESIGN-FLOW® High Density Polyethylene Pipe Fittings meet dimensions and requirements of FM 1613, ASTM D 3261, ASTM F 2206, ASTM F 714, ASTM D 3035, AWWA C901/C906 and NSF 61 standards as applicable.



FM DIPS Reducers (Dimensions in Inches)

STYLE A
“compact”

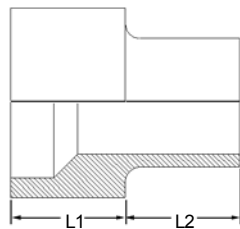

STYLE B
“fabricated”

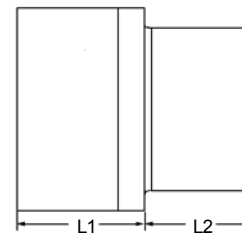

DIPS Nominal Size	Style	L1	L2	Class	DR	Weight (lbs)
4" x 3"	A	3.00	3.00	200	9	3
				150	11	2
6" x 4"	A	3.00	3.00	200	9	4
				150	11	3
8" x 6"	A	5.00	5.00	200	9	9
				150	11	8
10" x 8"	A	6.00	6.00	200	9	18
				150	11	15
12" x 10"	A	6.00	6.00	200	9	25
				150	11	21
14" x 12"	A	7.00	7.00	200	9	40
				150	11	33
16" x 14"	A	7.00	7.00	200	9	51
				150	11	43
18" x 16"	A	7.00	7.00	200	9	63
				150	11	52
20" x 18"	A	7.00	7.00	200	9	117
				150	11	96
24" x 20"	B	9.00	9.00	200	9	157
				150	11	129

FM APPROVED DESIGN-FLOW® High Density Polyethylene Pipe Fittings meet dimensions and requirements of FM 1613, ASTM D 3261, ASTM F 2206, ASTM F 714, ASTM D 3035, AWWA C901/C906 and NSF 61 standards as applicable.



FM IPS Branch Saddles (Dimensions in Inches)

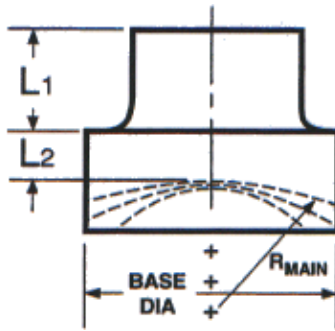

- FM Branch saddles are approved when fused to a straight run of pipe to form a tee. FM Branch Saddles are approved for use with pipe main diameters 3” to 48”.
- Branch saddle “blank” machined per order to radius of pipe main size ordered.
- Purchaser must determine that concave/convex heater plate adapters are available to complete the saddle fusion.

Outlet Nominal Size	Main Size Range	L1	L2	Base Diameter	Class	DR	Weight (lbs)
2" IPS	3 - 12	3.2	0.2	2.6	200	9	1
	14 - 34				150	11	1
	36 - 48						
3" IPS	4 - 12	3.2	0.5	3.9	200	9	2
	14 - 34				150	11	1
	36 - 48						
4" IPS	6 - 12	3.2	0.5	4.8	200	9	3
	14 - 34				150	11	2
	36 - 48						
6" IPS	8 - 12	3.2	0.8	7.3	200	9	5
	14 - 34				150	11	4
	36 - 48						
8" IPS	10 - 12	6.0	0.8	9.4	200	9	11
	14 - 34				150	11	9
	36 - 48						
10" IPS	12	6.0	1.0	11.5	200	9	19
	14 - 34				150	11	16
	36 - 48						
12" IPS	14 - 34	8.0	1.0	13.8	200	9	39
	36 - 48				150	11	32

FM APPROVED DESIGN-FLOW® High Density Polyethylene Pipe Fittings meet dimensions and requirements of FM 1613, ASTM D 3261, ASTM F 2206, ASTM F 714, ASTM D 3035, AWWA C901/C906 and NSF 61 standards as applicable.



FM DIPS Branch Saddles (Dimensions in Inches)

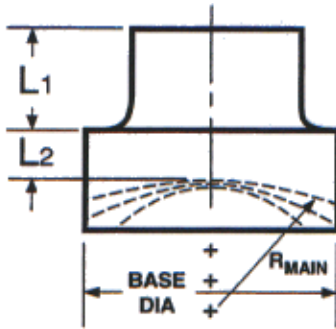

- FM Branch saddles are approved when fused to a straight run of pipe to form a tee. FM Branch Saddles are approved for use with pipe main diameters 3” to 48”.
- Branch saddle “blank” machined per order to radius of pipe main size ordered.
- Purchaser must determine that concave/convex heater plate adapters are available to complete the saddle fusion.

Outlet Nominal Size	Main Size Range	L1	L2	Base Diameter	Class	DR	Weight (lbs)
2" IPS	3 - 12 14 - 34 36 - 48	3.2	0.2	2.6	200 150	9 11	1 1
3" IPS/DIPS	4 - 12 14 - 34 36 - 48	3.2	0.5	3.9	200 150	9 11	2 1
4" DIPS	6 - 12 14 - 34 36 - 48	4.0	1.0	6.6	200 150	9 11	5 4
6" DIPS	8 - 12 14 - 34 36 - 48	5.0	1.5	8.6	200 150	9 11	11 9
8" DIPS	10 - 12 14 - 34 36 - 48	6.0	1.5	11.5	200 150	9 11	21 17
10" DIPS	12 14 - 34 36 - 48	8.0	2.0	13.8	200 150	9 11	38 31
12" DIPS	14 - 34 36 - 48	10.0	2.0	15.3	200 150	9 11	57 47

FM APPROVED DESIGN-FLOW® High Density Polyethylene Pipe Fittings meet dimensions and requirements of FM 1613, ASTM D 3261, ASTM F 2206, ASTM F 714, ASTM D 3035, AWWA C901/C906 and NSF 61 standards as applicable.

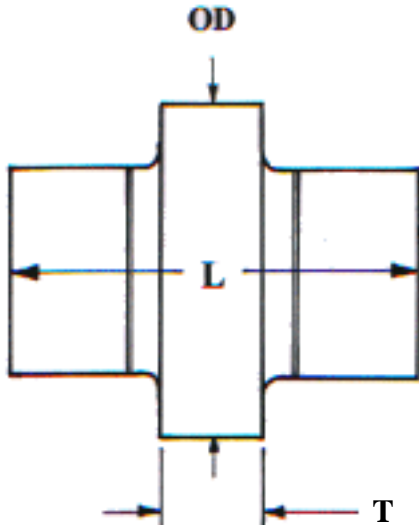

FM IPS & DIPS Water-Stop / Thrust-Isolator Wall-Pipe / Anchor Ring (Dimensions in Inches)

This pipeline component serves to restrain and anchor against thermal expansion and contraction as well as prevent “French” draining of water along the pipe OD. It is a multipurpose fitting used in several ways for different reasons - hence, several names for the same part. It is engineered to hold the pipe in place by transferring the thermal force from the pipe to the soil or vault wall via a large area of usually reinforced concrete. Make sure the soil bearing load area, as well as the thickness and strength of the concrete is sufficient.

IPS & DIPS Nominal Size	L	OD	T	Class	DR	Weight (lbs)
2" IPS	12.0	3.50	2.00	200	9	3
				150	11	2
3"	12.0	5.00	2.00	200	9	4
				150	11	3
4"	12.0	6.60	2.00	200	9	5
				150	11	4
6"	12.0	8.50	2.00	200	9	9
				150	11	7
8"	16.0	10.63	2.00	200	9	18
				150	11	15
10"	18.0	12.75	2.00	200	9	29
				150	11	24
12"	22.0	15.00	2.00	200	9	47
				150	11	39
14"	22.0	17.50	2.00	200	9	72
				150	11	59
16"	24.0	20.00	2.00	200	9	107
				150	11	88
18"	24.0	21.12	2.00	200	9	129
				150	11	106
20"	24.0	23.50	2.00	200	9	160
				150	11	131
22"	24.0	25.60	2.00	200	9	198
				150	11	163
24"	28.0	28.00	2.00	200	9	228
				150	11	187

FM APPROVED DESIGN-FLOW® High Density Polyethylene Pipe Fittings meet dimensions and requirements of FM 1613, ASTM D 3261, ASTM F 2206, ASTM F 714, ASTM D 3035, AWWA C901/C906 and NSF 61 standards as applicable.

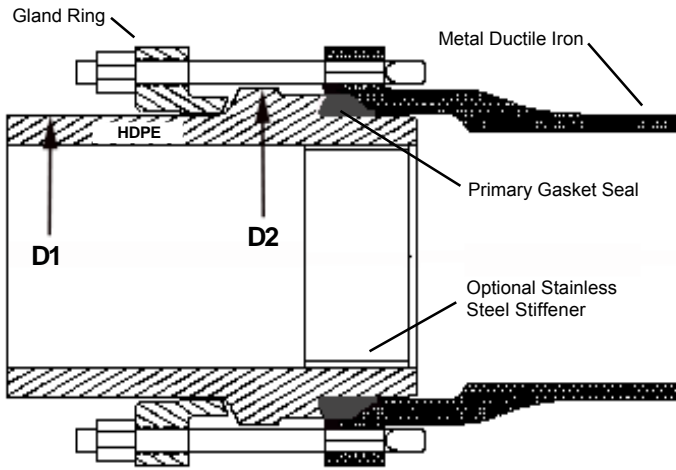

FM DIPS & IPS MJ Adapter With Kit

Connects HDPE to Ductile Iron
(Dimensions in Inches)

Kit includes HDPE anchor fitting, standard rubber gasket, extra length T-bolts, internal stainless steel stiffener (optional), C-110 heavy body ductile iron gland ring.

IPS & DIPS Nominal Size	D1 IPS	D1 DIPS	D2	OAL	Class	DR	Weight (lbs)
2" IPS	2.38	-	3.50	8.00	200 150	9 11	5
3"	3.50	3.96	5.37	8.50	200 150	9 11	8
4"	4.50	4.80	6.63	8.00	200 150	9 11	11
6"	6.63	6.90	8.63	9.50	200 150	9 11	17
8"	8.63	9.05	10.75	11.50	200 150	9 11	28
10"	10.75	11.10	12.75	13.00	200 150	9 11	36
12"	12.75	13.20	15.25	13.50	200 150	9 11	46
14"	14.00	15.30	17.50	13.50	200 150	9 11	85
16"	16.00	17.40	20.00	14.50	200 150	9 11	116
18"	18.00	19.50	22.00	16.00	200 150	9 11	123
20"	20.00	21.60	24.00	16.50	150	11	164
24"	24.00	25.80	28.00	18.00	150	11	222

Note: IPPI's MJ's incorporate a short nose design in order to work with most MJ butterfly valves, however it is recommended that specific valve information be supplied prior to ordering to insure proper clearance of the butterfly valve disc. MJ adapters should always be field tested for valve clearance before burial/final install. IPPI cannot be held responsible for valve interference with the MJ adapter. **Connections to PVC may require use of a D.I. solid sleeve (not included).

FM APPROVED DESIGN-FLOW® High Density Polyethylene Pipe Fittings meet dimensions and requirements of FM 1613, ASTM D 3261, ASTM F 2206, ASTM F 714, ASTM D 3035, AWWA C901/C906 and NSF 61 standards as applicable.

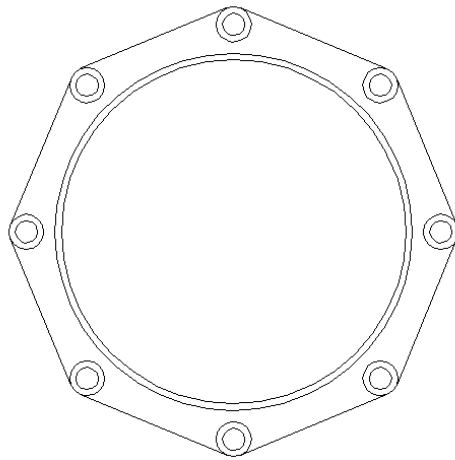

FM Ductile Iron MJ Adapter Gland & Accessory Pack

Kit includes extra long T-bolts, standard rubber gasket, C-110 heavy body ductile iron gland ring. For use with HDPE Mechanical Joint Adapter. Pressure rated for both Class 150 & Class 200.

Nominal Size	ID	Bolt Hole Circle	Number Of Holes	Bolt Hole Diameter	T-bolt Length	Body Thickness	Class	Weight (lbs)
2"	2.61	4.75	2	5/8	5.00*	1.37	200 150	4
3"	4.06	6.19	4	5/8	4.50*	1.37	200 150	6
4"	4.90	7.50	4	3/4	4.50	1.50	200 150	8
6"	7.00	9.50	6	3/4	5.00	1.63	200 150	11
8"	9.15	11.75	6	3/4	6.00	1.75	200 150	16
10"	11.20	14.00	8	3/4	6.00	1.75	200 150	18
12"	13.30	16.25	8	3/4	6.00	1.75	200 150	22
14"	15.44	18.75	10	3/4	7.00	2.00	200 150	48
16"	17.54	21.00	12	3/4	7.00	2.06	200 150	56
18"	19.64	23.25	12	3/4	7.00	2.13	200 150	67
20"	21.74	25.50	14	3/4	7.00	2.19	150	88
24"	25.94	30.00	16	3/4	7.00	2.31	150	106

Material is ductile iron and meets ASTM A536 GR 65/45/12 with asphalt based primer coating.

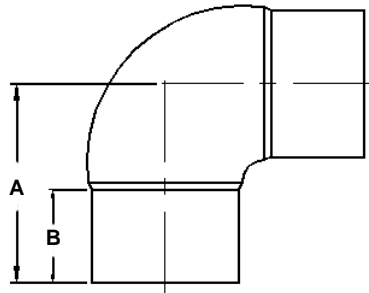

IPS Molded 90° Elbow

Fully Pressure Rated for DR Ordered
(Dimensions in Inches)

IPS Size	A	B	Class	SDR	Weight (lbs)
2"	4.50	2.500	200	9	1
			150	11	
3"	5.13	3.000	200	9	2
			150	11	
4"	5.75	3.000	200	9	3
			150	11	
6"	9.00	4.380	200	9	9
			150	11	

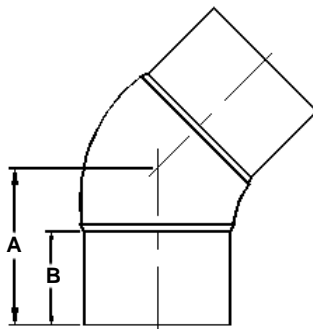

IPS Molded 45° Elbow

Fully Pressure Rated for DR Ordered
(Dimensions in Inches)

IPS Size	A	B	Class	SDR	Weight (lbs)
2"	3.23	2.64	200	9	1.5
			150	11	
3"	5.00	3.13	200	9	2
			150	11	
4"	5.00	3.13	200	9	3
			150	11	
6"	8.45	4.38	200	9	7
			150	11	

FM APPROVED DESIGN-FLOW® High Density Polyethylene Pipe Fittings meet dimensions and requirements of FM 1613, ASTM D 3261, ASTM F 2206, ASTM F 714, ASTM D 3035, AWWA C901/C906 and NSF 61 standards as applicable.

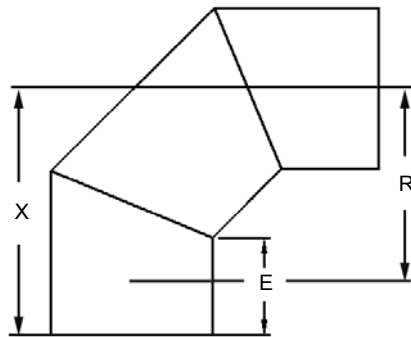

**FM IPS 90°
3 Segment Elbow
Fabricated (1/4 Bend)**
(Dimensions in Inches)

IPS Nominal Size	R/D Ratio	R	X	E	Class	SDR	Weight (lbs)
4"	1.5	6.8	10.9	6.0	200 150	7 9	7 6
6"	1.5	10.0	13.2	6.0	200 150	7 9	16 13
8"	1.25	10.7	14.6	6.5	200 150	7 9	29 23
10"	1.25	13.5	16.6	6.5	200 150	7 9	51 42
12"	1.25	16.0	20.0	8.0	200 150	7 9	84 68
14"	1.05	14.5	19.4	8.0	200 150	7 9	99 80
16"	1.05	16.8	21.2	8.0	200 150	7 9	138 112
18"	1.02	18.4	22.5	8.0	200 150	7 9	184 150
20"	1.02	20.4	24.1	8.0	200 150	7 9	241 196
22"	1.02	22.4	25.7	8.0	200 150	7 9	308 251
24"	1.02	24.5	27.3	8.0	200 150	7 9	394 320

FM APPROVED DESIGN-FLOW® High Density Polyethylene Pipe Fittings meet dimensions and requirements of FM 1613, ASTM D 3261, ASTM F 2206, ASTM F 714, ASTM D 3035, AWWA C901/C906 and NSF 61 standards as applicable.

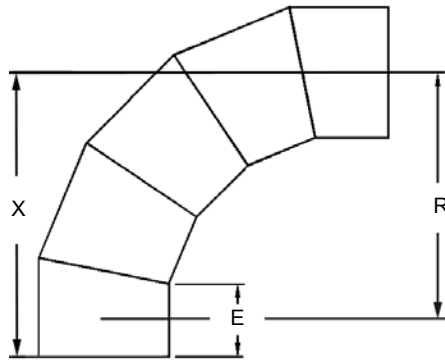

**FM IPS 90°
5 Segment Elbow
Fabricated (1/4 Bend)**
(Dimensions in Inches)

IPS Nominal Size	R/D Ratio	R	X	E	Class	SDR	Weight (lbs)
2"	5.40	12.7	14.4	4.0	200 150	7 9	2 2
3"	3.80	13.2	15.0	4.0	200 150	7 9	5 4
4"	3.00	13.7	15.5	4.0	200 150	7 917	9 8
6"	2.20	14.7	18.5	6.0	200 150	7 9	22 18
8"	1.80	16.0	20.2	6.5	200 150	7 9	40 32
10"	1.60	17.0	21.2	6.5	200 150	7 9	64 53
12"	1.50	19.1	24.6	8.0	200 150	7 9	103 84
14"	1.50	21.0	26.2	8.0	200 150	7 9	132 106
16"	1.50	24.0	28.8	8.0	200 150	7 9	185 151
18"	1.50	27.0	31.4	8.0	200 150	7 9	254 207
20"	1.50	30.0	34.0	8.0	200 150	7 9	335 270
22"	1.50	33.0	36.6	8.0	200 150	7 9	430 347
24"	1.50	36.0	39.2	8.0	200 150	7 9	538 437

FM APPROVED DESIGN-FLOW® High Density Polyethylene Pipe Fittings meet dimensions and requirements of FM 1613, ASTM D 3261, ASTM F 2206, ASTM F 714, ASTM D 3035, AWWA C901/C906 and NSF 61 standards as applicable.

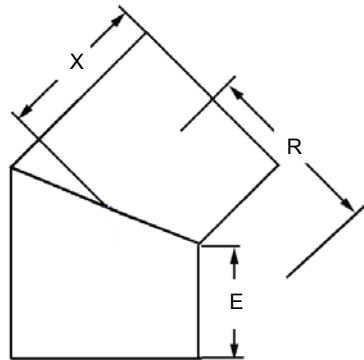

**FM IPS 45°
2 Segment Elbow
Fabricated (1/8 Bend)**
(Dimensions in Inches)

IPS Nominal Size	R/D Ratio	R	X	E	Class	SDR	Weight (lbs)
4"	1.5	6.8	6.9	6.0	200 150	7 9	3.5 3
6"	1.5	10.0	7.4	6.0	200 150	7 9	8 7
8"	1.25	10.7	8.3	6.5	200 150	7 9	19 15
10"	1.25	13.5	8.7	6.5	200 150	7 9	31 26
12"	1.25	16.0	10.6	8.0	200 150	7 9	52 42
14"	1.05	14.5	10.9	8.0	200 150	7 9	66 53
16"	1.05	16.8	11.3	8.0	200 150	7 9	86 70
18"	1.02	18.4	11.7	8.0	200 150	7 9	114 93
20"	1.02	20.4	12.1	8.0	200 150	7 9	148 119
22"	1.02	22.4	12.6	8.0	200 150	7 9	178 144
24"	1.02	24.5	13.0	8.0	200 150	7 9	221 180

FM APPROVED DESIGN-FLOW® High Density Polyethylene Pipe Fittings meet dimensions and requirements of FM 1613, ASTM D 3261, ASTM F 2206, ASTM F 714, ASTM D 3035, AWWA C901/C906 and NSF 61 standards as applicable.

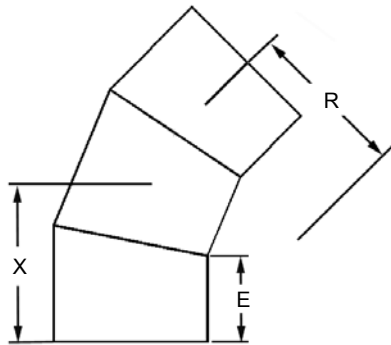

**FM IPS 45°
3 Segment Elbow
Fabricated (1/8 Bend)**
(Dimensions in Inches)

IPS Nominal Size	R/D Ratio	R	X	E	Class	SDR	Weight (lbs)
2"	5.4	12.7	6.6	4.0	200 150	7 9	1.5 1
3"	3.8	13.2	6.8	4.0	200 150	7 9	3 2
4"	3.0	13.7	7.0	4.0	200 150	7 9	6 5 4
6"	2.2	14.7	9.4	6.0	200 150	7 9	14 11
8"	1.8	16.0	10.3	6.5	200 150	7 9	24 19
10"	1.6	17.0	10.7	6.5	200 150	7 9	39 32
12"	1.5	19.1	12.8	8.0	200 150	7 9	62 51
14"	1.5	21.0	13.2	8.0	200 150	7 9	79 64
16"	1.5	24.0	14.0	8.0	200 150	7 9	112 91
18"	1.5	27.0	14.7	8.0	200 150	7 9	146 119
20"	1.5	30.0	15.5	8.0	200 150	7 9	187 151
22"	1.5	33.0	16.3	8.0	200 150	7 9	243 197
24"	1.5	36.0	17.0	8.0	200 150	7 9	298 240

FM APPROVED DESIGN-FLOW® High Density Polyethylene Pipe Fittings meet dimensions and requirements of FM 1613, ASTM D 3261, ASTM F 2206, ASTM F 714, ASTM D 3035, AWWA C901/C906 and NSF 61 standards as applicable.

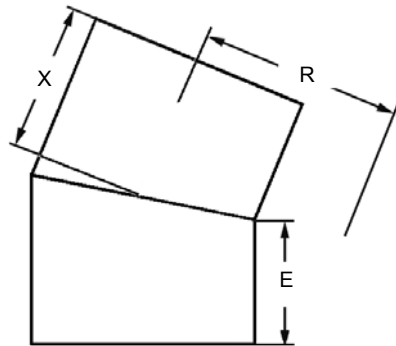

**FM IPS 22.5°
2 Segment Elbow
Fabricated (1/16 Bend)
(Dimensions in Inches)**

IPS Nominal Size	R/D Ratio	R	X	E	Class	SDR	Weight (lbs)
2"	1.5	3.6	4.3	4.0	200 150	7 9	1 1
3"	1.5	5.3	4.4	4.0	200 150	7 9	2 2
4"	1.5	6.8	4.5	4.0	200 150	7 9	3.5 3
6"	1.5	10.0	6.7	6.0	200 150	7 9	9 7
8"	1.25	10.7	7.4	6.5	200 150	7 9	16 13
10"	1.25	13.5	7.6	6.5	200 150	7 9	26 21
12"	1.25	16.0	9.3	8.0	200 150	7 9	43 35
14"	1.05	14.5	9.4	8.0	200 150	7 9	53 42
16"	1.05	16.8	9.6	8.0	200 150	7 9	73 61
18"	1.02	18.4	9.8	8.0	200 150	7 9	92 75
20"	1.02	20.4	10.0	8.0	200 150	7 9	114 92
22"	1.02	22.4	10.2	8.0	200 150	7 9	146 118
24"	1.02	24.5	10.4	8.0	200 150	7 9	173 141

FM APPROVED DESIGN-FLOW® High Density Polyethylene Pipe Fittings meet dimensions and requirements of FM 1613, ASTM D 3261, ASTM F 2206, ASTM F 714, ASTM D 3035, AWWA C901/C906 and NSF 61 standards as applicable.

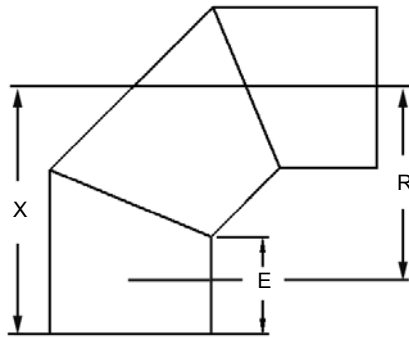

**FM DIPS 90°
3 Segment Elbows
Fabricated (1/4 Bend)**
(Dimensions in Inches)

DIPS Nominal Size	R/D Ratio	R	X	E	Class	SDR	Weight (lbs)
4"	1.5	7.2	11.2	6.0	200 150	7 9	10 8
6"	1.5	10.4	13.5	6.0	200 150	7 9	21 16
8"	1.25	11.3	15.0	6.5	200 150	7 9	33 27
10"	1.25	13.9	16.9	6.5	200 150	7 9	57 44
12"	1.25	16.5	20.4	8.0	200 150	7 9	97 75
14"	1.05	16.1	20.6	8.0	200 150	7 9	133 103
16"	1.05	18.3	22.3	8.0	200 150	7 9	182 141
18"	1.02	19.9	23.7	8.0	200 150	7 9	241 187
20"	1.02	22.0	25.4	8.0	200 150	7 9	307 239
24"	1.02	26.3	28.8	8.0	200 150	7 9	486 378

FM APPROVED DESIGN-FLOW® High Density Polyethylene Pipe Fittings meet dimensions and requirements of FM 1613, ASTM D 3261, ASTM F 2206, ASTM F 714, ASTM D 3035, AWWA C901/C906 and NSF 61 standards as applicable.

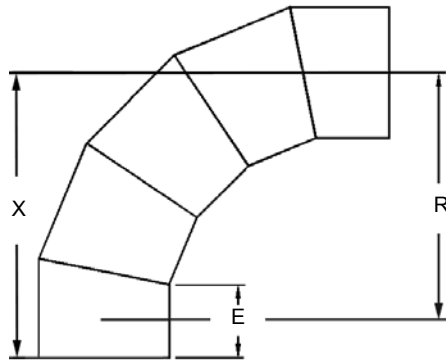

**DIPS 90°
5 Segment Elbow
Fabricated (1/4 Bend)**
(Dimensions in Inches)

DIPS Nominal Size	R/D Ratio	R	X	E	SDR	WPR	Weight (lbs)
4"	2.9	14.0	17.7	6.0	200 150	7 9	14 11
6"	2.2	15.0	18.7	6.0	200 150	7 9	27 21
8"	1.8	16.2	20.4	6.5	200 150	7 9	45 35
10"	1.6	17.2	21.4	6.5	200 150	7 9	72 56
12"	1.5	19.8	25.2	8.0	200 150	7 9	121 94
14"	1.5	23.0	28.0	8.0	200 150	7 9	173 134
16"	1.5	26.1	30.6	8.0	200 150	7 9	241 187
18"	1.5	29.3	33.4	8.0	200 150	7 9	329 256
20"	1.5	32.4	36.1	8.0	200 150	7 9	422 328
24"	1.5	38.7	41.6	8.0	200 150	7 9	683 531

FM APPROVED DESIGN-FLOW® High Density Polyethylene Pipe Fittings meet dimensions and requirements of FM 1613, ASTM D 3261, ASTM F 2206, ASTM F 714, ASTM D 3035, AWWA C901/C906 and NSF 61 standards as applicable.

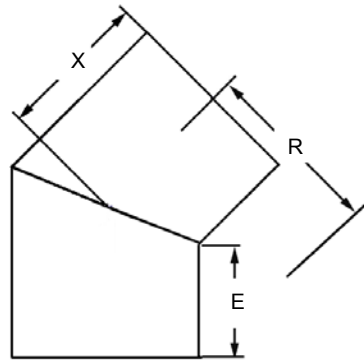

DIPS 45°
2 Segment Elbows
Fabricated (1/16 Bend)
 (Dimensions in Inches)

DIPS Size	R/D Ratio	R	X	E	SDR	WPR	Weight (lbs)
4"	1.5	7.2	7.0	6.0	7 9	200 150	7 5
6"	1.5	10.4	7.4	6.0	7 9	200 150	13 10
8"	1.25	11.3	8.4	6.5	7 9	200 150	22 17
10"	1.25	13.9	8.8	6.5	7 9	200 150	35 27
12"	1.25	16.5	10.7	8.0	7 9	200 150	59 46
14"	1.05	16.1	11.2	8.0	7 9	200 150	83 64
16"	1.05	18.3	11.6	8.0	7 9	200 150	111 86
18"	1.02	19.9	12.0	8.0	7 9	200 150	140 109
20"	1.02	22.0	12.5	8.0	7 9	200 150	179 139
24"	1.02	26.3	13.3	8.0	7 9	200 150	266 207

FM APPROVED DESIGN-FLOW® High Density Polyethylene Pipe Fittings meet dimensions and requirements of FM 1613, ASTM D 3261, ASTM F 2206, ASTM F 714, ASTM D 3035, AWWA C901/C906 and NSF 61 standards as applicable.

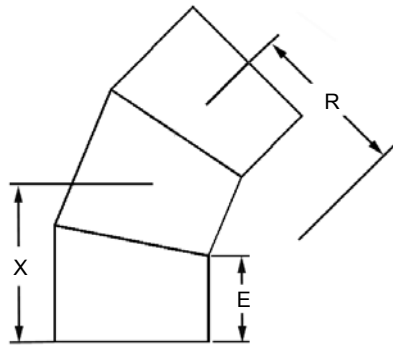

DIPS 45°
3 Segment Elbows
Fabricated (1/8 Bend)
 (Dimensions in Inches)

DIPS Size	R/D Ratio	R	X	E	SDR	WPR	Weight (lbs)
4"	2.9	14.0	9.1	6.0	7 9	200 150	8 6
6"	2.2	15.0	9.4	6.0	7 9	200 150	17 13
8"	1.8	16.2	10.4	6.5	7 9	200 150	27 21
10"	1.6	17.2	10.8	6.5	7 9	200 150	44 34
12"	1.5	19.8	13.0	8.0	7 9	200 150	75 58
14"	1.5	23.0	13.8	8.0	7 9	200 150	103 80
16"	1.5	26.1	14.5	8.0	7 9	200 150	143 111
18"	1.5	29.3	15.3	8.0	7 9	200 150	188 146
20"	1.5	32.4	16.1	8.0	7 9	200 150	235 183
24"	1.5	38.7	17.7	8.0	7 9	200 150	370 288

FM APPROVED DESIGN-FLOW® High Density Polyethylene Pipe Fittings meet dimensions and requirements of FM 1613, ASTM D 3261, ASTM F 2206, ASTM F 714, ASTM D 3035, AWWA C901/C906 and NSF 61 standards as applicable.

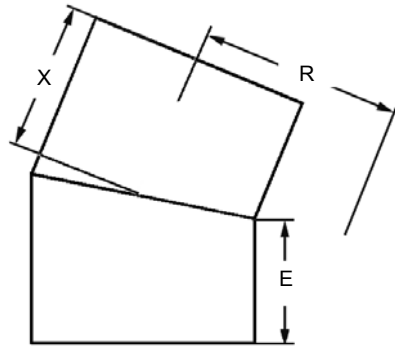

DIPS 22.5°
2 Segment Elbows
Fabricated (1/16 Bend)
 (Dimensions in Inches)

DIPS Size	R/D Ratio	R	X	E	SDR	WPR	Weight (lbs)
4"	1.5	7.2	6.5	6.0	7 9	200 150	5 4
6"	1.5	10.4	6.7	6.0	7 9	200 150	12 9
8"	1.25	11.3	7.4	6.5	7 9	200 150	18 14
10"	1.25	13.9	7.6	6.5	7 9	200 150	31 24
12"	1.25	16.5	9.3	8.0	7 9	200 150	50 39
14"	1.05	16.1	9.5	8.0	7 9	200 150	72 56
16"	1.05	18.3	9.7	8.0	7 9	200 150	88 69
18"	1.02	19.9	9.9	8.0	7 9	200 150	114 89
20"	1.02	22.0	10.1	8.0	7 9	200 150	147 114
24"	1.02	26.3	10.6	8.0	7 9	200 150	208 162

FM APPROVED DESIGN-FLOW® High Density Polyethylene Pipe Fittings meet dimensions and requirements of FM 1613, ASTM D 3261, ASTM F 2206, ASTM F 714, ASTM D 3035, AWWA C901/C906 and NSF 61 standards as applicable.



IPS Molded Line Tee

Fully Pressure Rated for DR Ordered
(Dimensions in Inches)

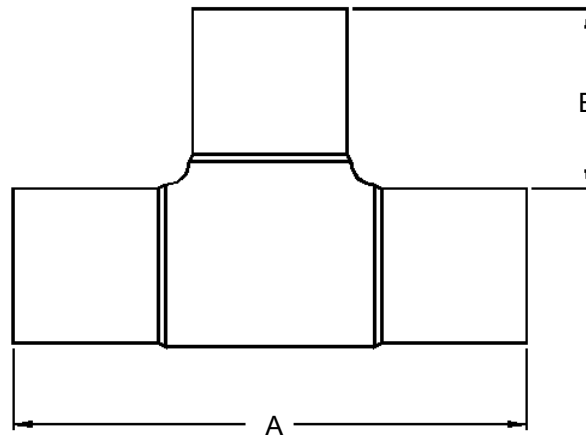

IPS Size	A	B	Class	SDR	Weight (lbs)
2"	9.00	3.31	200	9	2
			150	11	
3"	10.26	3.38	200	9	3
			150	11	
4"	11.20	3.35	200	9	4
			150	11	
6"	18.00	5.69	200	9	15
			150	11	

FM APPROVED DESIGN-FLOW® High Density Polyethylene Pipe Fittings meet dimensions and requirements of FM 1613, ASTM D 3261, ASTM F 2206, ASTM F 714, ASTM D 3035, AWWA C901/C906 and NSF 61 standards as applicable.

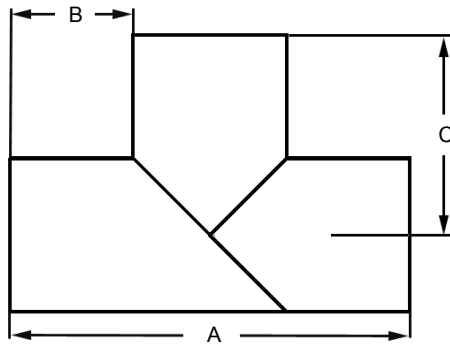

FM IPS Fabricated Line Tee (Dimensions in Inches)

IPS Nominal Size	A	B	C	Class	SDR	Weight (lbs)
4"	16.5	6.0	8.3	200 150	7 9	8 7
6"	18.6	6.0	9.3	200 150	7 9	19 15
8"	24.6	8.0	12.3	200 150	7 9	42 34
10"	26.8	8.0	13.4	200 150	7 9	70 57
12"	28.8	8.0	14.4	200 150	7 9	105 85
14"	32.0	9.0	16.0	200 150	7 9	140 112
16"	34.0	9.0	17.0	200 150	7 9	204 166
18"	38.0	10.0	19.0	200 150	7 9	283 231
20"	40.0	10.0	20.0	200 150	7 9	368 297
22"	46.0	12.0	23.0	200 150	7 9	506 409
24"	48.0	12.0	24.0	200 150	7 9	983 507

FM APPROVED DESIGN-FLOW® High Density Polyethylene Pipe Fittings meet dimensions and requirements of FM 1613, ASTM D 3261, ASTM F 2206, ASTM F 714, ASTM D 3035, AWWA C901/C906 and NSF 61 standards as applicable.

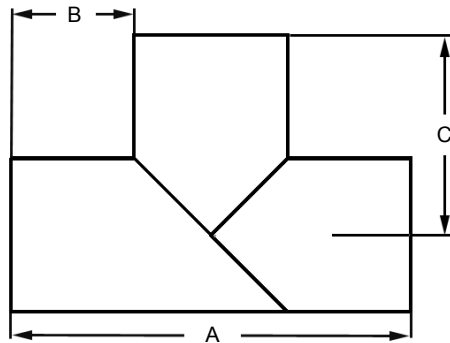

FM DIPS Fabricated Line Tee

(Dimensions in Inches)

DIPS Nominal Size	A	B	C	Class	SDR	Weight (lbs)
4"	16.8	6.0	8.4	200 150	7 9	12 9
6"	18.9	6.0	9.5	200 150	7 9	24 18
8"	25.0	8.0	12.5	200 150	7 9	48 37
10"	27.1	8.0	13.6	200 150	7 9	80 62
12"	29.2	8.0	14.6	200 150	7 9	119 93
14"	33.3	9.0	16.7	200 150	7 9	193 150
16"	35.4	9.0	17.7	200 150	7 9	264 205
18"	39.5	10.0	19.8	200 150	7 9	369 286
20"	41.6	10.0	20.8	200 150	7 9	462 359
24"	49.8	12.0	24.9	200 150	7 9	787 612

FM APPROVED DESIGN-FLOW® High Density Polyethylene Pipe Fittings meet dimensions and requirements of FM 1613, ASTM D 3261, ASTM F 2206, ASTM F 714, ASTM D 3035, AWWA C901/C906 and NSF 61 standards as applicable.

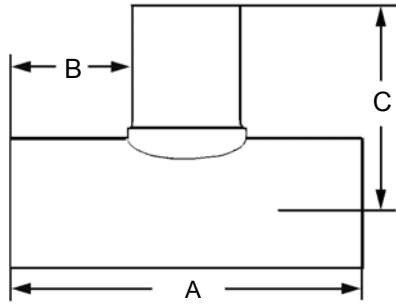

FM IPS Branch Saddle Reducing Tee Full Pressure Rated* (Dimensions in Inches)

IPS Nominal Size	A	B	C	Class	DR	IPS Nominal Size	A	B	C	Class	DR
4" x 2"	18.0	7.2	11.3	200 150	7 11	16" x 8"	32.0	10.6	27.8	200 150	7 11
4" x 3"	18.0	6.7	12.3	200 150	7 11	16" x 10"	34.0	10.6	28.0	200 150	7 11
6" x 2"	18.0	7.2	13.3	200 150	7 11	16" x 12"	36.0	10.5	30.0	200 150	7 11
6" x 3"	18.0	6.7	13.3	200 150	7 11	18" x 2"	24.0	10.2	18.5	200 150	7 11
6" x 4"	19.0	6.7	13.3	200 150	7 11	18" x 3"	24.0	9.7	19.3	200 150	7 11
8" x 2"	18.0	7.2	13.8	200 150	7 11	18" x 4"	27.0	10.2	19.0	200 150	7 11
8" x 3"	18.0	6.7	14.6	200 150	7 11	18" x 6"	29.0	10.2	18.6	200 150	7 11
8" x 4"	19.0	6.2	14.3	200 150	7 11	18" x 8"	32.0	10.6	28.6	200 150	7 11
8" x 6"	21.0	6.2	14.3	200 150	7 11	18" x 10"	34.0	10.6	29.0	200 150	7 11
10" x 2"	18.0	7.2	14.4	200 150	7 11	18" x 12"	36.0	10.5	31.0	200 150	7 11
10" x 3"	18.0	6.7	15.9	200 150	7 11	20" x 2"	28.0	12.2	19.5	200 150	7 11
10" x 4"	19.0	6.2	15.4	200 150	7 11	20" x 3"	29.0	12.2	20.3	200 150	7 11
10" x 6"	21.0	6.2	15.4	200 150	7 11	20" x 4"	31.0	7.2	20.0	200 150	7 11
10" x 8"	24.0	6.6	24.4	200 150	7 11	20" x 6"	33.0	12.2	19.6	200 150	7 11
12" x 2"	20.0	8.2	15.4	200 150	7 11	20" x 8"	36.0	12.6	29.6	200 150	7 11
12" x 3"	21.0	8.2	16.4	200 150	7 11	20" x 10"	38.0	12.6	30.0	200 150	7 11
12" x 4"	23.0	8.2	16.4	200 150	7 11	20" x 12"	40.0	12.5	32.0	200 150	7 11
12" x 6"	24.0	7.7	16.4	200 150	7 11	22" x 2"	28.0	12.2	20.5	200 150	7 11
12" x 8"	28.0	8.6	25.4	200 150	7 11	22" x 3"	29.0	12.2	21.3	200 150	7 11
12" x 10"	30.0	8.6	26.4	200 150	7 11	22" x 4"	31.0	7.2	21.0	200 150	7 11
14" x 2"	20.0	8.2	16.7	200 150	7 11	22" x 6"	33.0	12.2	20.6	200 150	7 11
14" x 3"	21.0	8.2	17.5	200 150	7 11	22" x 8"	36.0	12.6	30.6	200 150	7 11
14" x 4"	23.0	8.2	17.2	200 150	7 11	22" x 10"	38.0	12.6	31.2	200 150	7 11
14" x 6"	24.0	7.7	17.0	200 150	7 11	22" x 12"	40.0	12.5	33.0	200 150	7 11
14" x 8"	28.0	8.6	26.8	200 150	7 11	24" x 2"	28.0	12.2	21.5	200 150	7 11
14" x 10"	30.0	8.6	27.0	200 150	7 11	24" x 3"	29.0	12.2	22.3	200 150	7 11
14" x 12"	32.0	8.5	29.0	200 150	7 11	24" x 4"	31.0	7.2	22.0	200 150	7 11
16" x 2"	24.0	10.2	17.7	200 150	7 11	24" x 6"	33.0	12.2	21.6	200 150	7 11
16" x 3"	24.0	9.7	18.5	200 150	7 11	24" x 8"	36.0	12.6	31.6	200 150	7 11
16" x 4"	27.0	10.2	18.2	200 150	7 11	24" x 10"	38.0	12.6	32.20	200 150	7 11
16" x 6"	29.0	10.2	18.0	200 150	7 11	24" x 12"	40.0	12.5	34.0	200 150	7 11

*Class 200 IPS Branch Saddle Reducing Tee's incorporate a de-rated design which uses a standard base branch saddle and heavier feedstock for the main and the outlet piping.

FM APPROVED DESIGN-FLOW® High Density Polyethylene Pipe Fittings meet dimensions and requirements of FM 1613, ASTM D 3261, ASTM F 2206, ASTM F 714, ASTM D 3035, AWWA C901/C906 and NSF 61 standards as applicable.

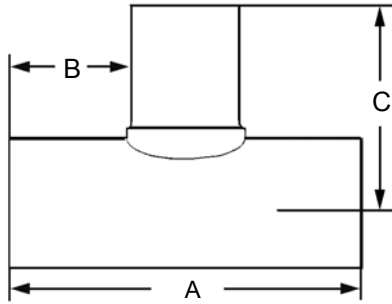

FM DIPS Branch Saddle Reducing Tee Full Pressure Rated* (Dimensions in Inches)

DIPS Nominal Size	A	B	C	Class	DR	DIPS Nominal Size	A	B	C	Class	DR
6" x 4"	19.0	6.2	13.3	200 150	7 11	16" x 10"	34.0	10.1	28.0	200 150	7 11
8" x 4"	19.0	6.2	14.3	200 150	7 11	16" x 12"	36.0	10.4	30.0	200 150	7 11
8" x 6"	21.0	6.2	14.3	200 150	7 11	18" x 4"	27.0	10.2	19.7	200 150	7 11
10" x 4"	19.0	6.2	15.4	200 150	7 11	18" x 6"	29.0	10.2	20.2	200 150	7 11
10" x 6"	21.0	6.2	15.4	200 150	7 11	18" x 8"	32.0	10.2	29.2	200 150	7 11
10" x 8"	24.0	6.2	24.4	200 150	7 11	18" x 10"	34.0	10.1	29.7	200 150	7 11
12" x 4"	23.0	8.2	16.6	200 150	7 11	18" x 12"	36.0	10.4	31.7	200 150	7 11
12" x 6"	24.0	7.7	16.4	200 150	7 11	20" x 4"	31.0	12.2	20.8	200 150	7 11
12" x 8"	28.0	8.2	25.4	200 150	7 11	20" x 6"	33.0	12.2	21.3	200 150	7 11
12" x 10"	30.0	8.6	26.4	200 150	7 11	20" x 8"	36.0	12.2	30.3	200 150	7 11
14" x 4"	23.0	8.2	17.6	200 150	7 11	20" x 10"	38.0	12.1	30.8	200 150	7 11
14" x 6"	24.0	7.7	17.0	200 150	7 11	20" x 12"	40.0	12.4	32.8	200 150	7 11
14" x 8"	28.0	8.2	27.1	200 150	7 11	24" x 4"	31.0	12.2	22.9	200 150	7 11
14" x 10"	30.0	8.1	27.0	200 150	7 11	24" x 6"	33.0	12.2	23.4	200 150	7 11
14" x 12"	32.0	8.4	29.0	200 150	7 11	24" x 8"	36.0	12.2	32.4	200 150	7 11
16" x 4"	28.0	10.2	18.7	200 150	7 11	24" x 10"	38.0	12.1	32.9	200 150	7 11
16" x 6"	29.0	10.2	18.0	200 150	7 11	24" x 12"	40.0	12.4	34.9	200 150	7 11
16" x 8"	32.0	10.2	28.2	200 150	7 11						

*Class 200 IPS Branch Saddle Reducing Tee's incorporate a de-rated design which uses a standard base branch saddle and heavier feedstock for the main and the outlet piping.

FM APPROVED DESIGN-FLOW® High Density Polyethylene Pipe Fittings meet dimensions and requirements of FM 1613, ASTM D 3261, ASTM F 2206, ASTM F 714, ASTM D 3035, AWWA C901/C906 and NSF 61 standards as applicable.

INDEPENDENT PIPE PRODUCTS, INC.

DESIGN-FLOW®



“Better by Design”®

**FM Approved HDPE Pipe & Fittings
Submittal Catalog**

June 1, 2010 - Version 1.4.2